

# The Effect of Servant Leadership on The Quality of Education And The Characteristics of Millennial Teachers

**Imaduddin<sup>1</sup>, Hendri Putra<sup>2</sup>, Tukiyo<sup>3</sup>, Abdul Wahab<sup>4</sup>, Ahmat Nurulloh<sup>5</sup>**

<sup>1</sup>Islamic Educational Management Department, Institut Agama Islam Darullughah Wadda'wah, Pasuruan, East Java, Indonesia

<sup>2</sup>Educational Management Department, Universitas Negeri Medan, Deli Serdang, North Sumatra, Indonesia

<sup>3</sup>Teacher Professional Education Department, Universitas Widya Dharma Klaten, Klaten, Central Java, Indonesia

<sup>4</sup>Islamic Education Department, Universitas Muslim Indonesia, Makassar, South Sulawesi, Indonesia

<sup>5</sup>Senior High School Tra Vinh, Vietnam

Email: Imaduddunsabran77@gmail.com<sup>1</sup>, Hendriputra2378@gmail.com<sup>2</sup>

Tukiyo@unwidha.ac.id<sup>3</sup> Wahab79@umi.ac.id<sup>4</sup> nurulloh93@gmail.com<sup>5</sup>

---

DOI: <http://doi.org/10.33650/al-tanzim.v6i4.4069>

---

Received: May 2022

Accepted: August 2022

Published: September 2022

---

## Abstract:

Leadership, at this time, has methods of leadership styles including democratic, transformational, authoritarian, delegative, visionary, and servant leadership that can be applied in leading an organization. One method of leadership style is servant leadership. Human resource management in the education sector still needs to be improved to attain the quality of education. Education quality is influenced by servant leadership and millennial teacher characteristics. This study aims to determine the characteristics of millennial teachers as an intervening variable. This research was conducted at the Ma'arif NU Education Foundation Talang Pasuruan with a total sample of 104 respondents. The data used are primary data obtained directly from respondents through questionnaires and the respondents are all teachers at the Ma'arif NU Talang Education Foundation which consists of the Madrasah Ibtidaiyah, Madrasah Tsanawiyah, and Madrasah Aliyah educational institutions. The test results show that servant leadership affects the quality of education, the characteristics of millennial teachers affect the quality of education, and finally, the characteristics of millennial teachers can mediate servant leadership on the quality of education.

**Keywords:** *Servant Leadership, Quality Education, Characteristic Millennial Teacher*

## Abstrak:

Kepemimpinan pada saat ini memiliki banyak metode gaya kepemimpinan meliputi kepemimpinan demokratis, transformasional, otoriter, delegatif, visioner dan servant yang dapat diterapkan dalam memimpin sebuah organisasi. Salah satu metode gaya kepemimpinan adalah kepemimpinan servant. Manajemen sumber daya manusia bidang Pendidikan masih perlu ditingkatkan guna meningkatkan mutu pendidikan. Mutu Pendidikan dipengaruhi oleh kepemimpinan servant dan karakteristik guru milenial. Penelitian ini bertujuan untuk mengetahui karakteristik guru milenial sebagai intervening variable. Penelitian ini dilakukan di Yayasan Pendidikan Ma'arif NU Talang Pasuruan dengan jumlah sampel sebanyak 104 responden. Data yang

digunakan merupakan data primer yang didapatkan langsung dari responden melalui kuesioner dan yang menjadi responden adalah seluruh guru di Yayasan Pendidikan Ma'arif NU Talang yang terdiri atas Lembaga Pendidikan Madrasah Ibtidaiyah, Madrasah Tsanawiyah dan Madrasah Aliyah. Hasil uji menunjukkan bahwa kepemimpinan servant berpengaruh terhadap mutu Pendidikan, karakteristik guru milenial berpengaruh terhadap mutu Pendidikan dan yang terakhir karakteristik guru milenial mampu memediasi kepemimpinan servant terhadap mutu Pendidikan.

**Kata Kunci:** *Kepemimpinan Layanan, Mutu Pendidikan, Karakteristik Guru Milenial*

## INTRODUCTION

The quality of schools during the COVID-19 pandemic saw a decline in student grades. This was revealed by the head of the Jogjakarta city education, youth, and sports office, Budi Santosa Asrori (Baharun et al., 2021; Nasution et al., 2021). To maintain the quality of education, it is necessary to have a good relationship between the principal and the teacher so that there is no conflict (Liebowitz & Porter, 2019; Suchyadi & Nurjanah, 2018). So that it can affect the quality of schools. In addition to the leadership factor, there are also millennial teacher characteristics that affect the quality of education (Devi & Subiyantoro, 2021; Muali et al., 2022). With the facts that have been mentioned, it is necessary to conduct a study that specifically discusses servant leadership, millennial teachers, and the quality of education (Pawar et al., 2020).

Service Leadership is a holistic leadership approach that involves followers in various dimensions (eg relational, ethical, emotional, and spiritual) so that they are empowered to become what they want to be, (Eva et al., 2019) Service leadership affects the quality of education because not all leaders can manage well. (Mulyadi, 2010) revealed that servant leadership has a significant and positive influence on improving teacher performance, and improving the quality of learning (Yolanda, 2020). The generation of millennial employees, including teachers, affects the quality of education. (Sapengga, 2016) and (Irving, 2010) reveals that there are 5 indicators of service leadership, namely love, humility, vision, trust, and empowerment. Leadership has a very large role in the management of the organization which has an impact on the quality of education. Such as research conducted by (Dian et al., 2022) and (Bashori, 2019). Research conducted by (Mulyadi, 2010) and (Tambunan et al., 2014), found that servant leadership has a positive impact on teacher performance, organization, and learning quality. In line with that, the servant leadership model is considered suitable for today's educational philosophy (Mufassir et al., 2019).

Educational quality or quality is one thing that must be owned by every educational institution, as regulated in article 1 paragraph 1 PP no. 32 of 2013 which affirms that "The National Education Standard is the minimum criterion regarding the education system in all jurisdictions of the unitary state of the Republic of Indonesia. Suryana (2020) revealed that the problems of education quality include human resources and the government's commitment to education. According to (Kuntoro, 2019), revealed that there are three things to see the quality of schools, both private schools, and public schools. The first is

that schools have commitment, concern, and awareness that quality is important, the second has the initiative and creativity to improve the quality, and lastly, having strong leadership and getting parental support (Fatchurochman, 2021; Ma'arif et al., 2022). Education quality standards refer to national education standards which include 8 things, namely content standards, processes, graduate competencies, education personnel, facilities and infrastructure, management, financing, and assessment of education (Triwiyanto, 2013).

Teachers are important figures in the education process that takes place in schools because teachers are the printers of quality and moral future generations. The image and concept of teachers in the millennial era are very different from the concept of the past (Mucharomah, 2017). Millennial teachers are known as a dynamic generation and have the ability and love for the previous generation (Suryahadikusumah & Kurniasari, 2019). Millennials have characteristics that have connected, confident and creative indicators that affect the quality of an organization (Alsup, 2019; Mäkinen et al., 2018; Tang et al., 2020).

Looking at the condition of servant leadership, the quality of education and the characteristics of millennial teachers, this study has objectives, namely, how the relationship between servant leadership and the quality of education is how the characteristics of millennial teachers affect the quality of education and how the relationship between servant leadership and quality education regarding the characteristics of millennial teachers is.

Based on the facts above, while servant leadership affects the quality of education, the characteristics of millennial teachers affect the quality of education and, servant leadership has a significant effect on the quality of education through the characteristics of millennial teachers. The difference between this study and previous research lies in the characteristics of millennial teachers as an intervening variable, where previous research analyzed the effect of a direct relationship between the characteristics of millennial teachers on the quality of education.

## RESEARCH METHOD

This research uses a quantitative approach with a survey conducted to examine the relationship and direct influence between exogenous and endogenous variables through intervening variables (Given, 2012). The exogenous variable of this research is servant leadership ( $X_1$ ), (Sapengga, 2016) and (Irving, 2010) reveals that there are 5 indicators of service leadership, namely love, humility, vision, trust, and empowerment. the endogenous variable is the quality of education ( $Y_2$ ), indicators of education quality are standards of content, process, competency of graduates, education staff, facilities and infrastructure, management, financing, and assessment of education (Triwiyanto, 2013). and the intervening variable is the characteristics of millennial teachers ( $Y_1$ ), indicators Millennial characteristics have connected, confident and creative that affect the quality of an organization (Alsup, 2019; Mäkinen et al., 2018; Tang et al., 2020). This research is located at the NU Ma'arif Education Foundation, Talang Pasuruan.

The population in this study was the Educational Institutions at the Ma'arif NU Talang Pasuruan Education Foundation which consisted of MI (*Madrasah Ibtidaiyah*), MTs (*Madrasah Tsanawiyah*), and MA (*Madrasah Aliyah*) Education while the research sample consisted of all 104 teachers at the Foundation. This sample is called the census method, because it takes the entire population, (Muhyi et al., 2018) data collection is done by distributing questionnaires that have been tested for validity and reliability on all question items.

The data used are primary data obtained directly from respondents through questionnaires distributed to respondents (Sugiyono, 2008). Questionnaires distributed to respondents have been tested for validity and reliability. Validity test using Pearson's product-moment correlation. Its formula is as follows:

$$r = \frac{N(\sum XY) - (\sum X)(\sum Y)}{\sqrt{[N\sum X^2 - (\sum X)^2][N\sum Y^2 - (\sum Y)^2]}}$$

Information

r= correlation coefficient

X= Item Score

Y= Item Total Score

N= Sample Total (Respondent)

Reliability Test

Because the number of respondents was more than 100, this study used Structural Equation Modeling (SEM) analysis (Hair Jr et al., 2010). The stages of SEM analysis include developing a concept or theory-based model, constructing a path diagram, converting a path diagram to a structural model, evaluating the goodness of fit index, interpretation, and modification. Next, test the three hypotheses.

## FINDINGS AND DISCUSSION

The structural equation model (SEM) test for confirmatory factor analysis of exogenous servant leadership variables (X1) showed the results of factor loading values X1.1 = 0.82, X1.2 = 0.75, X1.3 = 0.74, X1.4 = 0.77 and X1.5 = 0.71. Because the overall factor loading value is > 0.50, the five indicators can be used to form the servant leadership variable. The value of the results of confirmatory factor analysis of the Intervening Characteristics of Millennial Teachers (Y1) shows the following results: The value of the loading factor of Millennial Teachers' Characteristics is variable Y1.1 = 0.81, Y1.2 = 0.84, and Y1.3 = 0.76 . The value of the loading factor of the three millennial teacher indicators is > 0.5, then the three indicators can be used as a forming variable for the characteristics of millennial teachers, while the results obtained in the confirmatory factor analysis of the education quality variable (Y2) get the results: Y2.1 = 0.81, Y2.2 = 0.78, Y2.3 = 0.72, Y2.4 = 0.65, Y2.5 = 0.80, Y2.6 = 0.66, Y2.7 = 0.75 and Y2.8 = 0.70. The loading factor value obtained > 0.50 means that the eight indicators of education quality can be used as a form of education quality variable. While the results of the full model analysis can be seen in Figure 1.

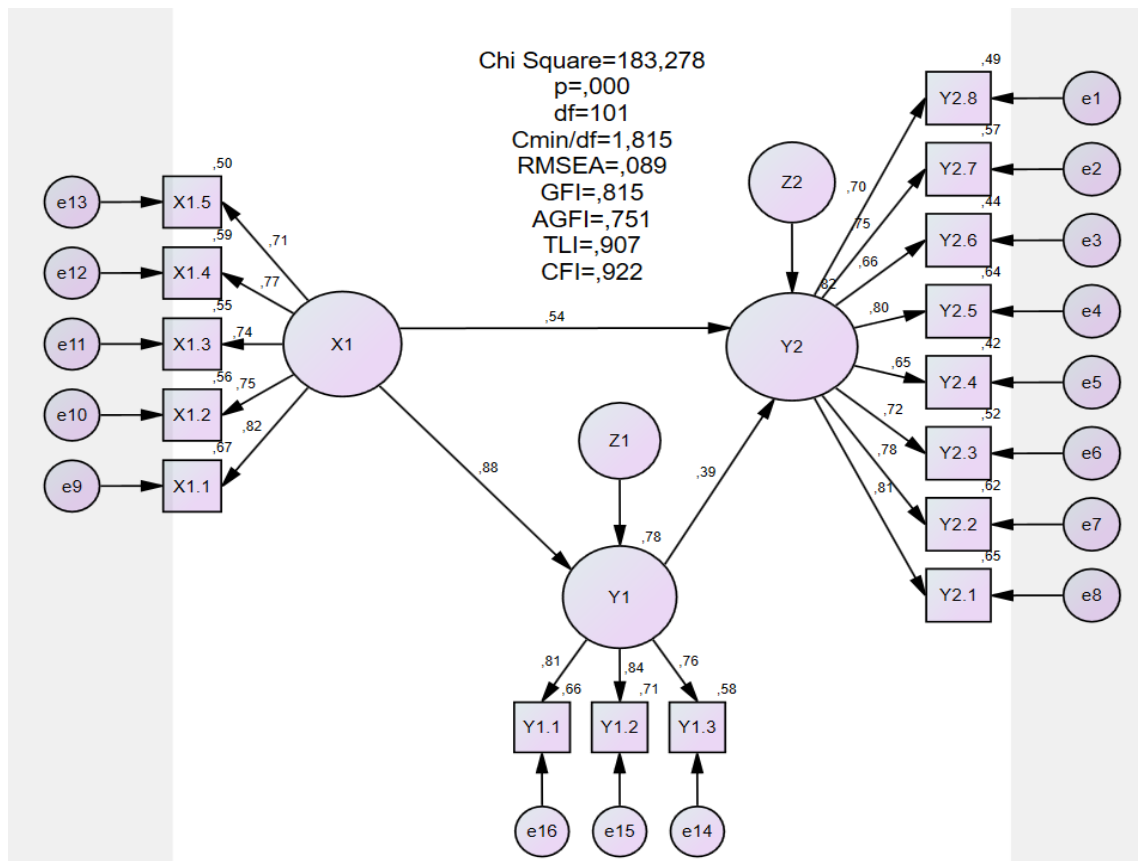

**Figure 1: Full Model SEM**

Figure 1 shows that the value of the servant leadership coefficient (X1) on the characteristics of millennial teachers (Y1) is 0.88. The coefficient of servant leadership (X1) on the quality of education (Y2) has a value of 0.54, while the coefficient on the characteristics of millennial teachers (Y1) on the quality of education (Y2) has a value of 0.39.

The results of the suitability test and statistical test for the full sem model can be seen in table 1.

**Table 1: SEM Model Fit Test Results**

<i>Goodness of fit index</i>	<i>Cut off Value</i>	<b>Analisis result</b>	<b>Model Evaluation</b>
<i>Chi-Square</i>	Expected to be smaller than <i>Chi-Square</i> ( $X^2$ tabel), with sig. $\alpha = 0,05$ , and $df = 183,278$ so $X^2$ table = 230,746.	183,278	Great
<i>Probability</i>	$\geq 0,05$	0,480	Great
<b>CMIN/DF</b>	$\leq 2.00$	1,815	Great
<b>GFI</b>	$\geq 0,90$	0,815	Great
<b>AGFI</b>	$\geq 0,90$	0,751	Marginal
<b>TLI</b>	$\geq 0,95$	0,907	Great
<b>CFI</b>	$\geq 0,95$	0,922	Great

Based on the results obtained in general, it can be concluded that in general the SEM model used can be categorized as good to describe the causality of the factors used.

**Table 2: Normality Assumption Test Results**

Variable	min	max	skew	c.r.	kurtosis	c.r.
Y1.1	2,000	5,000	,860	2,339	1,188	2,473
Y1.2	2,000	5,000	,839	2302	1,128	2,348
Y1.3	2,000	5,000	,623	2,292	,648	1,349
X1.5	2,000	5,000	,550	2,290	,696	1,449
X1.4	2,000	5,000	,267	1,110	-,206	-,428
X1.3	2,000	5,000	,445	1,855	,143	,297
X1.2	2,000	5,000	,555	2,312	,448	,932
X1.1	2,000	5,000	,593	2,467	1,036	2,157
Y2.1	2,000	5,000	,804	2,348	1,148	2,389
Y2.2	2,000	5,000	,660	2,247	1,120	2,330
Y2.3	2,000	5,000	,643	2,177	,951	1,979
Y2.4	2,000	5,000	,590	2,458	1,047	2,179
Y2.5	2,000	5,000	,915	1,809	1,567	2,262
Y2.6	2,000	5,000	,808	1,362	1,440	2,397
Y2.7	2,000	5,000	,346	1,440	,292	,609
Y2.8	2,000	5,000	,308	1,282	,201	,418
Multivariate					2,321	,493

The results of the normality test obtained the value of cr between -2.58 - 2.58 so that all questions on the indicators of each variable were normally distributed.

**Table 3: Hypothesis Testing Results**

			Estimate	S.E.	C.R	P	Information
Y1	<---	X1	,891	,118	7,533	***	Significant
Y2	<---	X1	,493	,181	3,720	***	Significant
Y2	<---	X1	,350	,176	2,988	***	Significant

Based on table 3, it can be proved as follows: 1) Test the first hypothesis of servant leadership on the quality of education. The critical ratio value of 7.533 shows that it is greater than 2 which is a condition for accepting the hypothesis, while the p value is less than 0.05 as a condition for accepting the hypothesis. Based on this value, it can be stated that servant leadership on the quality of education has been tested.

Test the second hypothesis of the characteristics of millennial teachers on the quality of education. The critical ratio value of 3.720 shows that it is greater than 2 which is a condition for accepting the hypothesis, while the p value is less than 0.05 as a condition for the hypothesis to be accepted. Based on this value, it can be stated that the characteristics of millennial teachers on the quality of education have been tested.

Test the third hypothesis of servant leadership on the quality of education through the characteristics of millennial teachers. Testing the third hypothesis of servant leadership on the quality of education through the characteristics of millennial teachers can be seen in table 4.



**Table 4: Effect Test Result**

Variable	Servant Leadership (X)	Millennial Teacher Characteristics (Y1)	Quality of Education (Y2)
Standardized Direct Effect			
Millennial Teacher Characteristics (Y1)	0.88	0	0
Quality of Education (Y2)	0.54	0.39	0
Standardized Total Effect			
Quality of Education (Y2)	0.805	0.402	0

**Source: Processed Primary Data**

Based on the results of direct influence and total influence, it can be proven that the total influence between variables is greater than the direct effect, the third hypothesis which states that servant leadership affects the quality of education through the characteristics of millennial teachers. The love indicator is the biggest value that forms the service leadership variable. The results of the study revealed that servant leadership which consists of indicators of love, humility, vision, trust and empowerment has a significant influence on the quality of education. These results strengthen the research that has been done (Mufassir et al., 2019), where . Indicator of love is the biggest value in forming servant leadership. Love is meant is sincerity to do the right thing at the right time to give the best reasons and decisions.

Quality of Education is formed on indicators of standard content, processes, competence of graduates, education staff, facilities and infrastructure, management, financing, and assessment of Education and is the largest reflection of the standards of educational content (Idris et al., 2022; Sa'dullah & Hidayatullah, 2020). These results indicate that the Ma'arif NU Talang Pasuruan Education Foundation provides teaching materials and levels of competence in accordance with the level of education.

The achievement of the quality of education is related to servant leadership at the Ma'arif NU Talang Pasuruan Education Foundation because, when making policies, someone who has service leadership is not only based on the authority (power) he has (Jondar, 2019) so that in the future become a leadership style that is suitable for the millennial generation. The millennial generation has very different characteristics from the previous generation.

The characteristics of millennial teachers who are formed are connected, confident and creative where the confidence indicator is the biggest reflection of connected and creative indicators (Alugar, 2021; Castillo, 2020). The self-confidence that is owned will be able to help the teacher adapt in carrying out new tasks. Good self-confidence can also create opportunities instead of waiting for opportunities to come and can also inspire enthusiasm to achieve organizational goals. This is in line with (Illahi, 2020), which reveals that the character of a good teacher affects the quality and quality of education.

The quality of education, which is influenced by the characteristics of millennial teachers, has a significant effect. This is because the characteristics of millennial teachers who have high self-confidence have a positive impact on the organization because they can reduce feelings of inferiority or feeling inferior when they find new jobs or are in a new environment. In addition, it can also

find new opportunities for innovation in organizational development. (Budimansyah, 2008) revealed that millennial teachers play a role in improving the quality of education because they always update information, because they are connected to the internet.

Servant leadership has a strong influence on the quality of education due to the role of the characteristics of millennial teachers who in their work have a desire to be connected, confident and creative (Heyler & Martin, 2018; Liao et al., 2021). Connected is meant to be actively connected globally and also able to create networks in a virtual world or in other words they like technology, the internet and so on. Confidence is feeling optimistic about what they are facing and lastly about being creative, namely the characteristics of millennial teachers who have high creativity because they have a sense of boredom because they were born in a different technological era compared to previous generations.

## CONCLUSION

Based on the SEM analysis, which was obtained through 104 respondents, it was found that servant leadership has an effect on the quality of education, and the characteristics of millennial teachers have a significant effect on the quality of education and finally, the characteristics of millennial teachers mediate servant leadership on the quality of education. The servant leadership indicators consist of love, humility, vision, trust and empowerment, the highest score is on the love indicator. The millennial characteristic indicators consist of connected, confident and creative and the confidence indicator gets the highest score. Education quality indicators consist of content standards, processes, competency of graduates, education staff, facilities and infrastructure, management, financing, and assessment of education and get the highest score on the content standard indicators.

The main finding of this research is on the characteristics of millennial teachers who are able to mediate servant leadership on the quality of education at the Ma'arif NU Talang Pasuruan Education Foundation. Where the previous researchers did not place the characteristics of millennial teachers as an intervening variable. This research was conducted in the field of Education, in order to obtain consistent results from this model, it is necessary to propose retesting in other fields such as industry or other fields.

## ACKNOWLEDGMENT

Thank you to the research team of the Indonesian Islamic Tarbiyah Lecturer Association based in Pasuruan. Thanks also to LPPM KH Abdul Halim Institute for providing collaboration time with alumni.

## REFERENCES

Alsop, J. (2019). *Millennial Teacher Identity Discourses: Balancing Self and Other*. Routledge. <https://doi.org/10.4324/9781351036542>



- Alugar, R. (2021). Experiences of Millennial Teachers in the Academe: A Phenomenological Inquiry. *International Journal of Education, Technology and Science*, 1(4), 119–131.
- Baharun, H., Hefniy, H., Silviani, S., Maarif, M. A., & Wibowo, A. (2021). Knowledge Sharing Management: Strategy for Improving the Quality of Human Resources. *Al-Tanzim: Jurnal Manajemen Pendidikan Islam*, 5(1), 129–139. <https://doi.org/10.33650/al-tanzim.v5i1.1831>
- Bashori, B. (2019). Kepemimpinan Transformasional Kyai pada Lembaga Pendidikan Islam. *Al-Tanzim : Jurnal Manajemen Pendidikan Islam*, 3(2), 73–84. <https://doi.org/10.33650/al-tanzim.v3i2.535>
- Budimansyah, D. (2008). Peningkatan Mutu Pendidikan melalui Penguatan Partisipasi Masyarakat. *Educationist*, 2(1), 56–63.
- Castillo, F. G. (2020). Innovative Pedagogy for Higher Educational Institution: The Teacher Point of View. In A. N. Al-Masri & Y. Al-Assaf (Eds.), *Sustainable Development and Social Responsibility – 2* (pp. 95–103). Springer International Publishing. [https://doi.org/10.1007/978-3-030-32902-0\\_13](https://doi.org/10.1007/978-3-030-32902-0_13)
- Devi, A. D., & Subiyantoro, S. (2021). Implementation of Democratic Leadership Style and Transformational Head of Madrasah in Improving The Quality. *Nidhomul Haq : Jurnal Manajemen Pendidikan Islam*, 6(1), 14–26. <https://doi.org/10.31538/ndh.v6i1.1162>
- Dian, D., Faizal, I., & Hasanah, N. D. (2022). Leadership and Capacity Building; The Construction of Madrasah Quality Improvement. *Al-Tanzim: Jurnal Manajemen Pendidikan Islam*, 6(1), 79–90. <https://doi.org/10.33650/al-tanzim.v6i1.3179>
- Eva, N., Robin, M., Sendjaya, S., van Dierendonck, D., & Liden, R. C. (2019). Servant Leadership: A Systematic Review and Call for Future Research. *Leadership Quarterly*, 30(1), 111–132. <https://doi.org/10.1016/j.leaqua.2018.07.004>
- Fatchurochman, N. (2021). Improving the Performance of Administrative Employees in Madrasah Aliyah Negeri 1 Serang Regency. *Nidhomul Haq : Jurnal Manajemen Pendidikan Islam*, 6(2), 331–341. <https://doi.org/10.31538/ndh.v6i2.1505>
- Given, L. (2012). The SAGE Encyclopedia of Qualitative Research Methods. *The SAGE Encyclopedia of Qualitative Research Methods*, 660–665. <https://doi.org/10.4135/9781412963909>
- Hair Jr, J. F., Babin, B. J., & Anderson, R. E. (2010). *A Global Perspective*. Kennesaw: Kennesaw State University.
- Heyler, S. G., & Martin, J. A. (2018). Servant Leadership Theory: Opportunities for Additional Theoretical Integration. *Journal of Managerial Issues*, 30(2), 230–243.
- Idris, A., Trisnamansyah, S., & Wasliman, I. (2022). Implementation of The Internal Quality Assurance System in Improving School Quality. *Munaddhomah: Jurnal Manajemen Pendidikan Islam*, 3(1), 27–34. <https://doi.org/10.31538/munaddhomah.v3i1.96>

- Illahi, N. (2020). Peranan Guru Profesional dalam Peningkatan Prestasi Siswa dan Mutu Pendidikan di Era Milenial. *Jurnal Asy-Syukriyyah*, 21(1), 1–20. <https://doi.org/10.36769/asy.v21i1.94>
- Irving, J. A. (2010). Cross-Cultural Perspectives on Servant Leadership. *Servant Leadership: Developments in Theory and Research*, 118–129. <https://doi.org/10.1057/9780230299184>
- Jondar, A. (2019). Implikasi Kepemimpinan Servant dalam Bidang Pendidikan. *Jurnal Penelitian Administrasi Publik*, 1, 105–112.
- Kuntoro, A. T. (2019). Manajemen Mutu Pendidikan Islam. *Jurnal Kependidikan*, 7(1), 84–97. <https://doi.org/10.24090/jk.v7i1.2928>
- Liao, C., Lee, H. W., Johnson, R. E., & Lin, S.-H. (Joanna). (2021). Serving You Depletes Me? A Leader-Centric Examination of Servant Leadership Behaviors. *Journal of Management*, 47(5), 1185–1218. <https://doi.org/10.1177/0149206320906883>
- Liebowitz, D. D., & Porter, L. (2019). The Effect of Principal Behaviors on Student, Teacher, and School Outcomes: A Systematic Review and Meta-Analysis of the Empirical Literature. *Review of Educational Research*, 89(5), 785–827. <https://doi.org/10.3102/0034654319866133>
- Ma'arif, M. A., Zuana, M. M. M., & Sirojuddin, A. (2022). Improving Islamic Self-Motivation for Professional Development (Study in Islamic Boarding Schools). In *Supporting Modern Teaching in Islamic Schools*. Routledge.
- Mäkinen, M., Linden, J., Annala, J., & Wiseman, A. (2018). Millennial Generation Preservice Teachers Inspiring The Design of Teacher Education. *European Journal of Teacher Education*, 41(3), 343–359. <https://doi.org/10.1080/02619768.2018.1448776>
- Muali, C., Ridwan, R., Huda, H., & Akbar, A. R. (2022). Improving Teacher Work Discipline in Madrasah Through Charismatic Leadership. *Al-Tanzim: Jurnal Manajemen Pendidikan Islam*, 6(1), 281–294. <https://doi.org/10.33650/al-tanzim.v6i1.3302>
- Mucharomah, M. (2017). Guru di Era Milenial dalam Bingkai Rahmatan Lil Alamin. *Edukasia Islamika*, 2(2), 172. <https://doi.org/10.28918/jei.v2i2.1667>
- Mufassir, Mohamad, R., & Mala, A. (2019). Model Kepemimpinan yang Melayani dalam Meningkatkan Mutu Pendidikan: Studi Servant Leadership Kepala Madrasah Aliyah Muhammadiyah kota Gorontalo. *Al-Minhaj: Jurnal Pendidikan Islam*, 2(1), 38–56.
- Muhyi, M., Hartono, Budiyo, S. C., Satianingsih, R., Sumardi, Rifai, I., Zaman, A. Q., Astutik, E. P., & Fitriatien, S. R. (2018). Metodologi Penelitian. *Metode Penelitian*, 1–83.
- Mulyadi, M. (2010). *Kepemimpinan kepala sekolah dalam mengembangkan budaya mutu*. UIN-Maliki Press.
- Nasution, M. R., Mesiono, M., & Hadijaya, Y. (2021). Management of The Academic Potential of Students During The Covid-19 Pandemic. *Nidhomul Haq: Jurnal Manajemen Pendidikan Islam*, 6(2), 470–482. <https://doi.org/10.31538/ndh.v6i2.1658>

- Pawar, A., Sudan, K., Satini, S., & Sunarsi, D. (2020). Organizational Servant Leadership: *International Journal of Educational Administration, Management, and Leadership*, 63–76. <https://doi.org/10.51629/ijeamal.v1i2.8>
- Sa'dullah, A., & Hidayatullah, M. F. (2020). Design of Improving The Quality of Human Resources Based on Islamic Schools in Anak Saleh Foundation, Malang City. *Nazhruna: Jurnal Pendidikan Islam*, 3(2), 260–272. <https://doi.org/10.31538/nzh.v3i2.740>
- Sapengga, S. E. (2016). Pengaruh Servant Leadership terhadap Kinerja Karyawan pada PT. Daun Kencana Sakti Mojokerto. *Agora*, 4(1), 645–650.
- Suchyadi, Y., & Nurjanah. (2018). Relationship between Principal Supervision in Increasing the Job Satisfaction of Private Junior High School Teachers in East Bogor District. *JHSS (Journal of Humanities and Social Studies)*, 2(1), 26–29. <https://doi.org/10.33751/jhss.v2i1.818>
- Sugiyono. (2008). *Metode Penelitian Pendidikan: (Pendekatan Kuantitatif, Kualitatif dan R & D)*. Bandung: Alfabeta.
- Suryahadikusumah, A. R., & Kurniasari. (2019). Karakteristik Guru BK Millennial di Sekolah Menengah Atas Kota Palembang. *Teraputik Jurnal Bimbingan dan Konseling*, 3(2), 52–27. <https://doi.org/10.30998/teraputik.32125>
- Suryana, S. (2020). Permasalahan Mutu Pendidikan dalam Perspektif Pembangunan Pendidikan. *Edukasi*, 14(1), 1–11. <https://doi.org/10.15294/edukasi.v14i1.971>
- Tambunan, M. P., Indonesia, U. P., Guru, K., Efektivitas, D., & Tahunan, P. (2014). *Pengaruh Servant Leadership Dan Kinerja Guru Terhadap*. 21(2), 1–10.
- Tang, S. Y. F., Wong, A. K. Y., Li, D. D. Y., & Cheng, M. M. H. (2020). Millennial Generation Preservice Teachers' Intrinsic Motivation to Become A Teacher, Professional Learning and Professional Competence. *Teaching and Teacher Education*, 96, 103180. <https://doi.org/10.1016/j.tate.2020.103180>
- Triwiyanto, T. (2013). Standar Nasional Pendidikan sebagai Indikator Mutu Layanan Manajemen Sekolah. *Jurnal Ilmu Pendidikan*, 19(2), 161–171.
- Yolanda, E. (2020). *Professional and Pedagogical Competence of Early Childhood Education Teachers in Millennial Era*. 66–70. <https://doi.org/10.2991/assehr.k.200715.013>